



# User manual

Applicable product model:

**CS-ARC-Q420A110/A111**

(CS-MRC-Q420AC01)

**CS-ARC-Q580A110/A111**

(CS-MRC-Q580AC01)



Shenzhen Coolingstyle Technology Co., Ltd.

## Contents

<b>1. APPEARANCE.....</b>	<b>2</b>
<b>2. BASIC PARAMETERS.....</b>	<b>3</b>
<b>3. OPERATION INSTRUCTIONS .....</b>	<b>4</b>
3.1 INSTALLATION .....	4
3.2 DISPLAY SETTING .....	5
3.3 DATA INTERFACE DESCRIPTION (OPTIONAL).....	7
3.4 FAULT CODE AND OUTPUT PORT DESCRIPTION .....	8
<b>4. PRECAUTIONS .....</b>	<b>10</b>
<b>5. SIMPLE TROUBLESHOOTING.....</b>	<b>12</b>
<b>6. DAILY MAINTENANCE .....</b>	<b>14</b>
<b>7. STANDARD FACTORY LIST .....</b>	<b>14</b>

# 1. Appearance

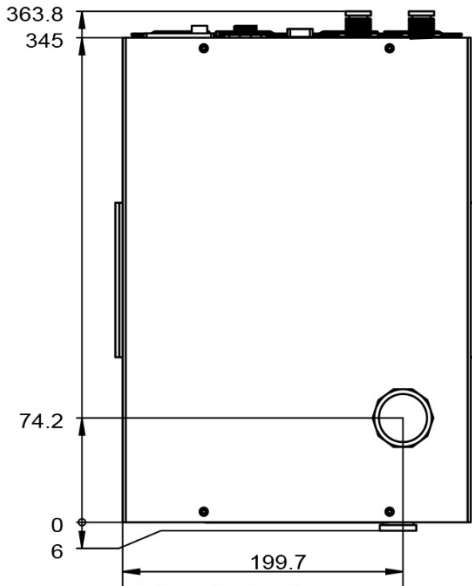
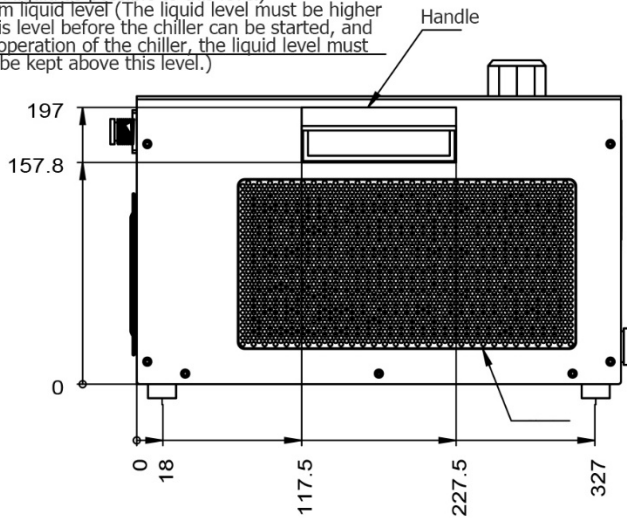
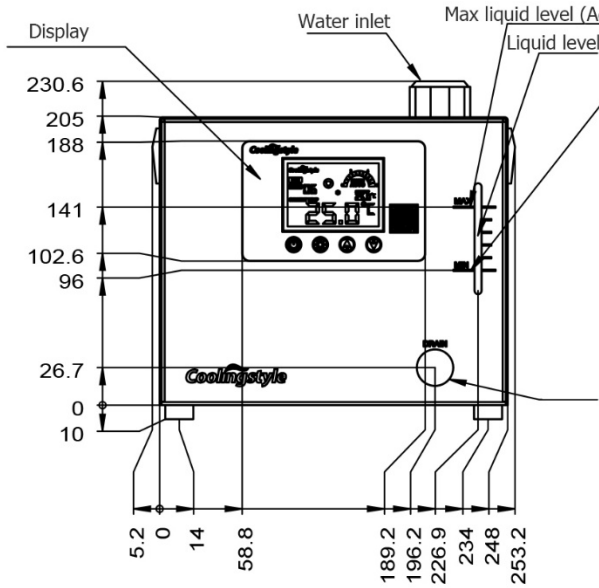

Power socket  
AC220V, AC110V is optional

Pins	Signal content
L	Live wire
N	Neutral line
E	Ground wire

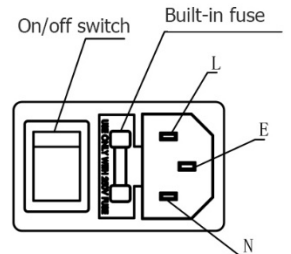

Alarm port (two ports are the same)

Chiller state	Signal content	
	Pin 1 and pin 2	Pin1 and pin 3
Normal working	Disconnect	Connect
Fault	Connect	Disconnect

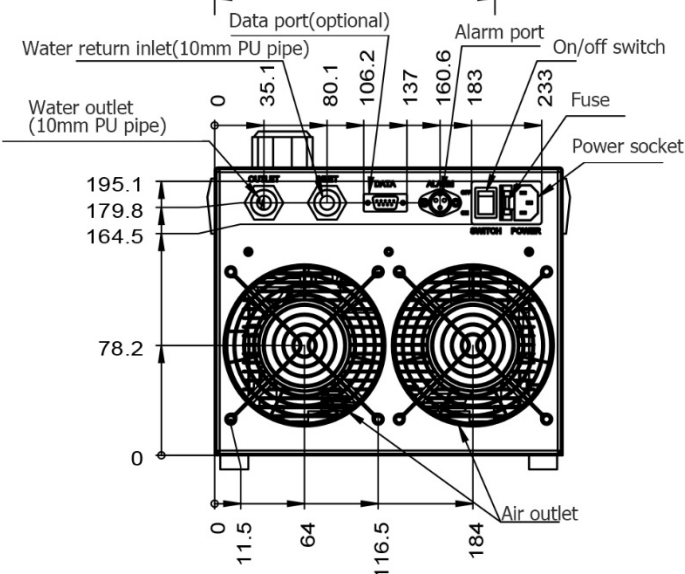
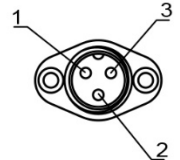

Signal port (RS485 communication is customizable)

Pins	Signal content
1	Unused
2	Unused
3	A
4	Unused
5	GND
6	Unused
7	Unused
8	B
9	Unused

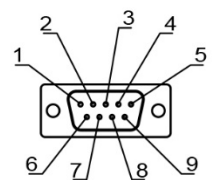

Unit: mm

## 2. Basic parameters

Product name	Micro chiller	Model	CS-ARC-Q420A110/A111		CS-ARC-Q580A110/A111	
Item		Unit	Value		Value	
Nominal cooling capacity		W	420		580	
Rated voltage/frequency		V/Hz	220/50-60, (110V is optional)			
Rated power		W	280	290	360	380
Pump	Head	m	13	20	20	25
	Max flow	L/min	23	24	24	25
Refrigerant	Type		R134a			
Water tank	Volume	L	1.8			
Temperature setting range		°C	10~35			
Temperature control accuracy		°C	±0.1			
Working temperature		°C	0~45			
Storage temperature		°C	-10~60			
Net weight		kg	10			
Gross weight		kg	12			
Fluid			Water/antifreeze			
Connector			10mm pneumatic joint			
Chiller size		mm	345*248*215			
Package size		mm	410*313*273			

### 3. Operation instructions

#### 3.1 Installation

Please follow the steps when the chiller is used for the first time:

1. Open the package and check if the machine is in good condition and the accessories are complete.
2. Open the cap and add water. Add pure water or other clean antifreeze until it is above the minimum liquid level. In order to achieve better performance, it is recommended to reach as close as possible to the highest liquid level, and the maximum water injection amount is about 1.8L.
3. Be sure to connect the external waterway before starting operation. The inlet and outlet are both 10mm pu pipe quick-plug connectors, if necessary, users can transfer it by themselves.
4. Connect the chiller to 220V power, and press the switch to power on. After power on, the chiller is in a stopped state. You need to operate the display screen to boot up, see the next section for details.
5. If the external pipeline is long, the water level will drop slightly after the first start-up. You can replenish a proper amount of fluid from the water injection port.

### 3.2 Display Setting

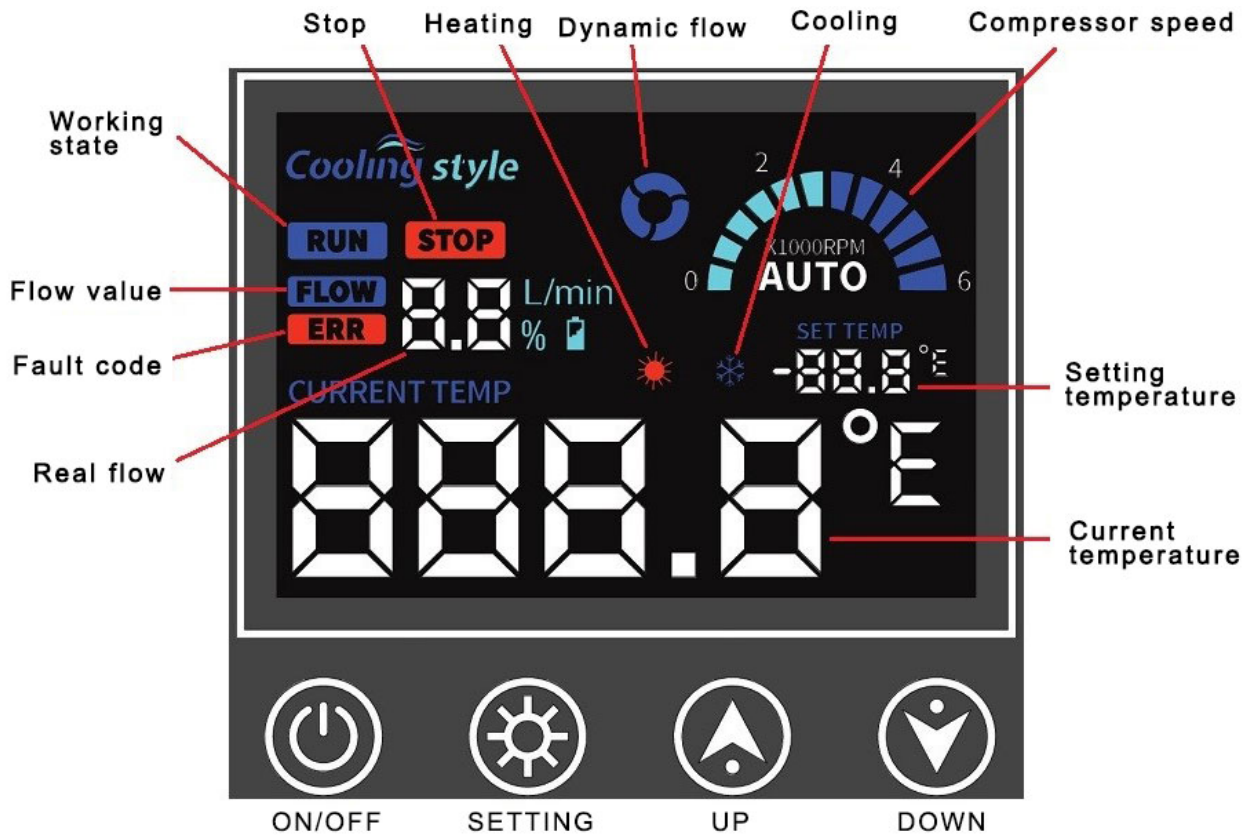

The display screen is divided into a display area and an operation area, as shown in the figure above.

**Display area** includes: RUN, STOP, ERROR, CHILLING, HEATING. Etc.



Working indication: when lit, it means the chiller is on (the AUTO indicator in the upper right corner lights up at the same time, indicating that the water temperature is under automatic control);



Stop indication: when lit, it indicates that the chiller is in the shutdown state (including power off and fault status);



Flow indication: indicates that the following number is water flow value;



This area displays 2 types of content:

- a) During normal operation, real-time traffic is displayed. When the flow rate is less than 10L/min, it is accurate to 0.1L/min; when the flow rate is greater than 10L/min, it is accurate to 1L/min.

b) In the fault state, the fault code is displayed.



Fault indication: when lit, it indicates that the chiller is in a fault state;



Dynamic flow indication: when the flow rate is not zero, the 3 arc-shaped icons will cyclically light up; when the flow rate is zero, all 3 arc-shaped icons will flash;



Compressor speed identification: Indicates the actual speed of the compressor. The scale value corresponding to the lighted icon multiplied by 1000 is the rotational speed value, and the unit is r/min.



Cooling indication: when lit, the compressor is working and the chiller is in the cooling state;



Heating indication: when lit, it indicates that the internal heating device is in working condition;



Setting value: Under normal circumstances, display the set target temperature; when setting the flow alarm threshold, display the flow threshold;



Real-time water temperature: indicates the current water temperature.

**Operation area:** There are 4 buttons. The buzzer will emit a short "beep" sound when pressed effectively, and there will be no response when pressed invalid. The specific instructions are as follows:



On/Off button: Press to turn on/off the chiller.



Setting button: click to enter the setting interface. The real-time flow area  shows: "F0", and each time pressing the set button, this area will cycle to display "F0", "F1", "F2", "F3" these 4 codes. "F0" means that the target temperature can be set at this state; "F1" means that the high temperature alarm value can be set at this state; "F2" means

that the low temperature alarm value can be set at this state; "F3" means that the flow alarm threshold can be set at this state. The set value will be displayed at this area



Press the setting button again on the "F3" interface, and the display will return to the normal display state. Stay on any setting interface of "F0", "F1", "F2", "F3" for more than 10 seconds without any operation, the display will also return to the normal display state. Specific instructions are shown in the following table:

Code	Set item	Range	Factory default setting	Remarks
F0	Set temperature	10-35°C	25°C	Target temperature
F1	High temperature alarm threshold	0.1-10	3°C	When the water temperature is higher than F0+F1, it will alarm and the alarm code will display "E5"
F2	Low temperature alarm threshold	0.1-10	3°C	When the water temperature is lower than F0-F2, it will alarm and the alarm code will display "E6"
F3	Flow alarm threshold	2-10L/min	3L/min	When the water flow rate is less than F3, it will alarm, and the alarm code will display "E4"



Up key: In the setting interface, when click, the set value (F0-F3) increases, and continuously increases when you press and hold.



There are 2 functions of this button:

- a) In the setting interface, click this button, the set value (F0-F3) will decrease, and the value will decrease continuously when pressed for a long time.
- b) In the state of E5 or E6 failure (see section 3.4), click this button, the buzzer alarm will be turned off for 10 minutes (the fault code displayed on the screen will not be eliminated, only the sound will be turned off).

### 3.3 Data interface description (optional)

The data interface is on the back cover of the chiller and it is a 9-pin serial port. When used for RS485 communication, the pins are defined as follows:

Function	Pins	
RS485	3——A, 8——B, 5——GND	 <p>DB9 Male Front side</p>

### 3.4 Fault code and output port description







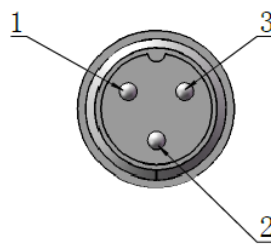



When the chiller is in a fault or alarm state, the fault status indicator on the display is lit, the flow



display area shows the fault code, and the buzzer alarms. At the same time, the signal interface outputs corresponding on-off signals. There are 2 signal ports (3-pin aviation plug) on the back cover of the chiller. The two output signals are exactly the same. By default, only signal port 1 has an output. You can customize both to output at the same time. The fault code description is shown in the following table:

Error code	Failure description	Buzzer	Signal pin 1, 2	Signal pin 1, 3
Normal			Disconnection	Connection
E1	Temperature sensor failure	Alarm repeating	Connection	Disconnection
E2	Temperature sensor failure	2 times alarm repeating	Connection	Disconnection
E3	Insufficient liquid level in water tank	3 times alarm repeating	Connection	Disconnection
E4	Water flow is 0 or below the threshold	4 times alarm repeating	Connection	Disconnection
E5	Water temperature is higher than high temperature alarm threshold	5 times alarm repeating	Connection	Disconnection
E6	Water temperature is lower than the low temperature alarm threshold	6 times alarm repeating	Connection	Disconnection
Definition of signal interface pins and wiring colors		 <p>Pin 1: red or brown; pin 2: blue; pin 3: yellow or yellow-green</p>		

#### 4. Precautions

-  Please ensure that the working voltage of the machine is stable, the power frequency is matched, the rated voltage of the machine is 220-240V, and the frequency is 50HZ.
-  Make sure that the power outlet is in good contact and that the ground wire is reliably grounded.
-  The system can use pure water or deionized water, do not let impurities fall into the water tank, it will affect the service life of the pump, and prohibit running the water pump without water.
-  The external connection pipe of the machine shall be free of wrinkles and folding, and the clamp shall be fixed at the interface.
-  The internal tank volume of the machine is about 1.8L. Please pay attention to add slowly when adding water to prevent a large amount of overflow;
-  It is strictly forbidden if the chiller is working when water level is under minimum liquid level.
-  The ambient temperature of the refrigeration system should not exceed 50°C, and should not be used in corrosive gas or liquid environment, so as not to affect the product life.
-  Pay attention to keep the air inlet and outlet of the chiller unobstructed. The air outlet behind the chiller should be more than 50cm away from the obstacle, and the front air inlet should be more than 30cm away from the obstacle.
-  When the water temperature is lower than the ambient temperature and the ambient humidity is high, condensation water will be generated on the circulating water pipe and the surface of the device to be cooled. When the above situation occurs, it is recommended to raise the water temperature or make thermal insulation for the water pipe and the device to be cooled.
-  The air inlet filter should be cleaned regularly (once a month).



Replace the circulating water every 45 days (to be drained in the shutdown state).



Touch display is made of glass, do not press hardly to prevent the display from shattering.



When shutting down, please turn off the chiller by the button first, then cut off the power after the pump stops.



If the machine has serious abnormal sound or other abnormal working conditions, please stop it and cut the power off. For technical problems, please contact the after-sales department;



Do not disassemble the machine without permission. Do not modify the machine for other purposes.



This product is an industrial device and should not be operated by non-professionals

## 5. Simple Troubleshooting

Fault	Reason	Troubleshooting
Turn on the chiller but the power is not connected	Power contact is not good	Check the power connector, whether the power cord plug is plugged in and in good contact.
	Glass fuse tube is blown	Replace the fuse inside the power connector on the back of the machine
Flow alarm (E4 Error code is displayed), directly connect the water outlet with a water pipe, no water flow at the return water outlet	Water tank water level is too low	Check the liquid window, add water to the minimum liquid level line; check if the water circulation line leaks, and if the water joint is loose
It shows flow alarm when the chiller is connected with power(E4 Error code is displayed), but when the water pipe is directly connected to the water outlet and there is water flow, and the flow alarm is disappeared.	There is blockage of the water circulation pipeline or the water pipe is bended	Check the water circulation line
It shows over-high temperature alarm (E5 error code is displayed)	The filter is blocked and the heat dispassion is not good.	Remove the filter and clean it regularly
	The ventilation is not good of the air outlet or air inlet	Ensure that the air inlet and outlet are well ventilated
	The voltage is severely low or unstable	Improve power supply lines or use a voltage regulator
	Heat load exceeded	Reduce heat load, or choose a larger cooling capacity chiller

<p>It shows over-low temperature alarm (E6 error code is displayed)</p>	<p>The set temperature is too high when the power is turned on, and the water temperature in the water tank is too low.</p>	<p>The system will adjust automatically</p>
<p>Condensed water condensation is serious</p>	<p>The water temperature is much lower than the ambient temperature and the humidity is high.</p>	<p>Increase the set temperature or make thermal insulation for the water pipe</p>
<p>Drainage is slow when changing water</p>	<p>The water inlet is not opened</p>	<p>Open the water inlet</p>

## 6. Daily Maintenance

1. Clean the air inlet filter regularly, once a month is recommended;

2. Regularly replace the circulating water, once every 45 days is recommended. The drain port is a quick-connect female connector. Open the cap of the filler and connect the standard male connector to the drain port to perform drainage operation. When draining, carry out pipeline cleaning work at the same time, you can perform the operation of "add water-running the chiller at a short time -drain", repeat 2 to 3 times; or use compressed air to blow and clean the remaining water in the pipeline.

## 7. Standard Factory List

No.	Name	Unit	Qty	Note
1	Chiller	unit	1	
2	Power cable	unit	1	
3	Signal cable	unit	1	
4	RS485 communication cable	unit	1	
5	User manual	unit	1	
6	Warranty card	pcs	1	
7	Quality certificate	pcs	1	

## Shenzhen Coolingstyle Technology Co., Ltd.

Room 901, Building 1, Guangming Digital Intelligent Manufacturing Park, Guangming District, Shenzhen, China.

Tel: 14063101121

Website: [www.coolingstyle.com](http://www.coolingstyle.com)

Email: [service@coolingstyle.com](mailto:service@coolingstyle.com)