

# 全封闭滚动转子式 直流调速压缩机规格书 Rotary DC Timing Compressors Specification

压缩机型号 TC2-M014Y4  
Compressor Model

用户名称 \_\_\_\_\_  
The Customer

空调器型号 \_\_\_\_\_  
Air-conditioner Model

	庆安签名 QINGAN SIGNATURE	用户签名 CUSTOMER'S APPROVAL
姓名		
时间		

本规格书从贵公司确认之日起生效。双方公司负责人承认签名之后请返回我公司一份。  
This specification will be valid from the date of the client's confirmation. Please send one copy of the specification to QINGAN after both parties' authorized signing.

编制 Compile: 武某 2018.5.16

审核 Examine: 周小华 2018.5.16

批准 Approve: 李峰 2018.5.16



西安庆安制冷设备股份有限公司

Xi'an Qingan Refrigeration Equipment Co., Ltd

1. 压缩机规格 **Specification of Compressor**1.1 适用范围 **Application Scope**

空调器类型 <b>Air-conditioner Type</b>	直流变频空调器 <b>Variable speed room air conditioners</b>
冷媒 <b>Refrigerant</b>	<b>R134a</b>
环境温度范围 <b>Range of Ambient temperature</b>	<b>-5~55℃</b>
蒸发温度范围 <b>Range of evaporating temperature</b>	<b>-10~15℃</b>
冷凝温度范围 <b>Range of Condensing temperature</b>	<b>45~76℃</b>
控制器外加电源规格 <b>Rated Voltage of Controller</b>	<b>24V DC</b>

1.2 基本规格 **Basic Specification**

压缩机类型 <b>Compressor Type</b>	全封闭型直流调速压缩机 <b>Rotary DC Timing Compressors</b>
排气容积 <b>Displacement</b>	<b>1.4cm<sup>3</sup>/rev</b>
气缸数 <b>Cylinder Number</b>	<b>1</b>
吸气管内径 <b>Suction Tube(I.D)</b>	<b>Φ6.5mm</b>
排气管内径 <b>Discharge Tube(I.D)</b>	<b>Φ6.0mm</b>
总重量（含润滑油） <b>Net Weight (Oil Included)</b>	<b>0.85 kg</b>
润滑油名称及油量 <b>Oil &amp; Oil Charge</b>	<b>RL68H &amp;55 ml</b>
涂装 <b>Painting</b>	黑色 <b>Black Color Paint</b>

1.3 电动机规格 **Specification of Motor**

电机型式 <b>Motor Type</b>	直流无刷电机 <b>BLDC Motor</b>	
启动方式 <b>Starting Type</b>	直流专用控制器启动 <b>DC Controller Starting</b>	
转子极数 <b>Rotor Pole</b>	6	
运行转速范围 <b>SpeedRange</b>	<b>2700~6300rpm</b>	
磁铁材料 <b>Magnet Material</b>	钕铁硼 <b>NdFeB</b>	
永磁体退磁电流峰值	32A	<b>120℃, -5%退磁率</b>

<b>Demagnetizing Current</b>		<b>At 120°C, -5% Demagnetizing rate</b>
<b>d 轴电感 Inductance-Ld</b>	0.15mH	额定电流下 <b>Under Rated Current</b>
<b>q 轴电感 (mH) Inductance-Lq</b>	0.25mH	额定电流下 <b>Under Rated Current</b>
定子线圈电阻 <b>Winding Resistance</b>	<b>0.3 Ω</b>	线间电阻 (20°C下) <b>line-to-line (at 20°C)</b>
感应电压常数 <b>Voltage Constant</b>	2.0 Vrms/krpm	线间电压 <b>line-to-line</b>
电机转矩常数 <b>Torque Constant</b>	0.036 N.m/Arms	
转动惯量 <b>Inertia</b>	1.43E-05kg.m <sup>2</sup>	
每极每相磁链 (Wb) <b>Flux linkage</b>	0.0066Wb	
磁通量 <b>Flux</b>	0.0175 ± 3% Wb	
控制器运转电压范围 <b>Controller Running Voltage range</b>	<b>24V ± 10%</b>	

## 2. 性能参数 Performance Parameter

### 2.1 测试工况及性能 Test Condition & Performance

名称 <b>Parts Name</b>	单位 <b>Unit</b>	名义值 <b>rating parameter</b>
制冷量 <b>Cooling Capacity</b>	W	<b>240 (at 4500 rpm)</b>
输入功率 <b>Input Power</b>	W	<b>105 (at 4500 rpm)</b>
能效比 <b>EER</b>	W/W	<b>2.4 (at 4500 rpm)</b>

#### 测试工况 Test Condition

- ◆ 冷凝温度 **Condensing temperature :54.4°C**
- ◆ 蒸发温度 **Evaporating temperature :7.2°C**
- ◆ 吸气温度 **Suction Gas temperature :35.0°C**
- ◆ 过冷度 **Degree of Super-cooling :8.3°C**
- ◆ 环境温度 **Ambient temperature :35°C**

## 2.2 起动、运转 Start &amp; Running

名称 Parts Name	单位 Unit	要求值 Numerical Value
退磁电流 Demagnetization amps	A	$\leq 32$
启动方式 Starting Type		直流专用控制器启动 DC Controller Starting
控制器运转电压范围 Controller Running Voltage range	V	$24 \pm 10\%$

## 2.3 其他特性 Else Characteristics

名称 Parts Name	单位 Unit	要求值 Numerical Value
气密试验压力 Leakage Testing Pressure	Mpa	2.12
筒体耐压试验压力 Shell Mechanical Strength Pressure	Mpa	7.42
绝缘等级 Insulation Class		B Class
绝缘电阻 Insulation Resistance	M $\Omega$	$\geq 30$
电气强度 Electric Strength		500V 1min or 600V 1sec
残余水分 Residual Moisture	mg	$\leq 15$
残余杂质 Residual Impurity	mg	$\leq 5$
接地电阻 Earthing Resistance	$\Omega$	$\leq 0.1$
制冷剂最大充注量 The Filling Max. Amount of Refrigerant	g	75

## 3. 制冷量/转速曲线 Refrigeration capacity/rotate speed cruve

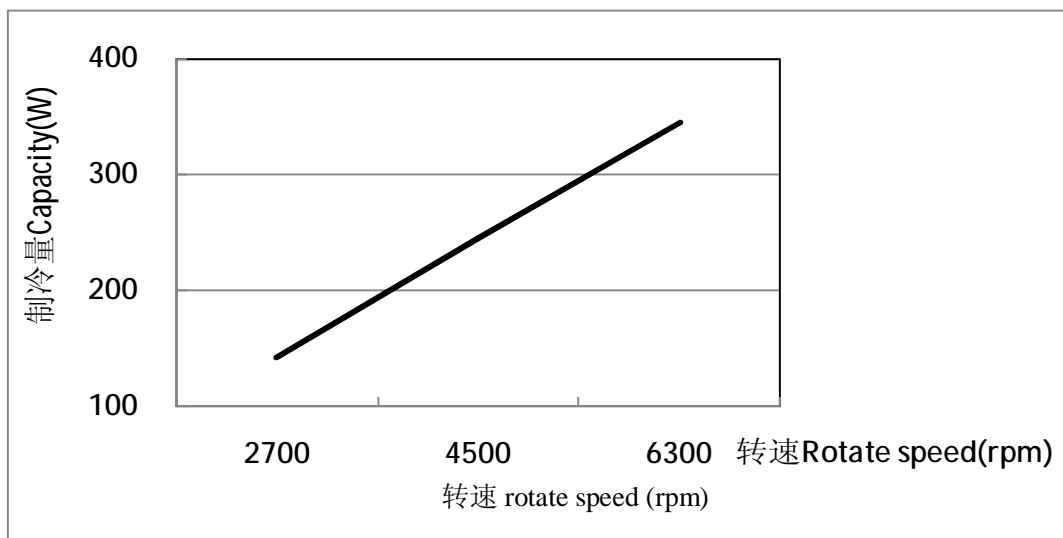

#### 4. 冷凝压力与转速特性 Condensing pressure and rotate speed characteristic

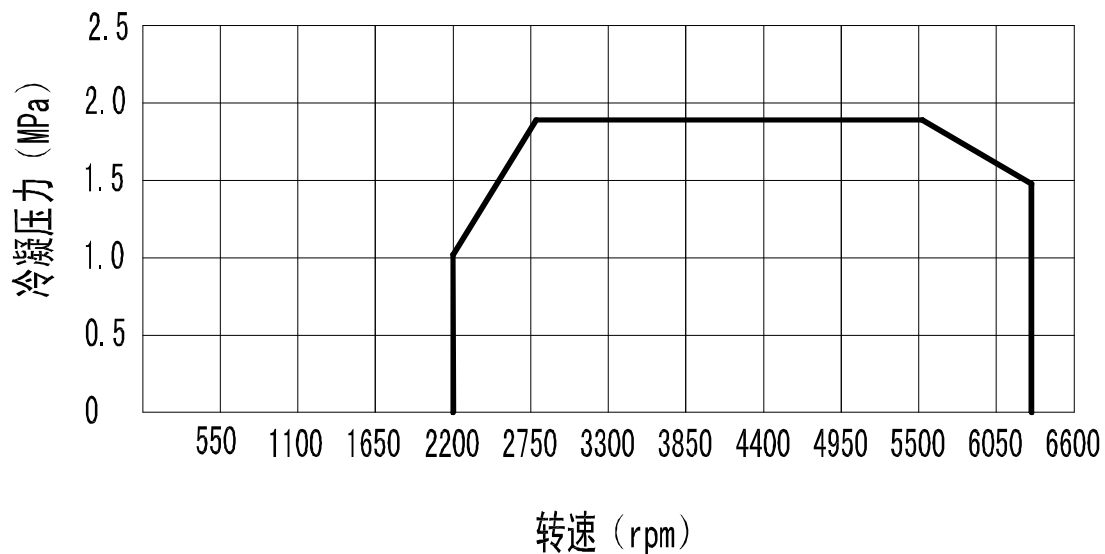

#### 5. 压缩机的使用极限 The ultimate using state of the compressor

##### 5.1 压缩比 Compression ratio

在任何允许运转的工况下，压缩机的压缩比应小于 6。

Under any working condition that allows normal operation, the compression ratio of the compressor should be less than 6.

##### 5.2 启动时压差 ( $\Delta P$ ) The difference of the press at starting ( $\Delta P$ )

压缩机启动时的高低腔压差 $\Delta P$  (=排气腔压力-吸气腔压力) 在 0.03Mpa 以下。

When starting, the difference between the high press and the low press of the compressor  $\Delta P$  (= pressure of the exhaust cavity - pressure of the suction cavity) should be below 0.03 Mpa.

##### 5.3 吸入气体干度 (X) The degree dryness of the suction gas (X)

$$X \geq 0.945$$

##### 5.4 转速的变化 Variation of rotation speed

###### 5.4.1 转速的变化率 Variation ratio of rotation speed

转速的上升速率应小于 120rpm/s，转速的变化幅度应在 120rpm/s 以内，为防止瞬间过电流，允许转速的最大下降速率为 120rpm/s。

The rising rate of rotation speed should be less than 120 rpm/s. The range of rotation speed variation should be within 120 rpm/s. In case of transient over-current, the reducing rate of rotation speed should be no more than 120 rpm/s.

###### 5.4.2 转速的变化模式 Variation Mode of Rotation Speed

###### 5.4.2.1 从停机到正常的转速模式如图 3。

The variation mode of rotation speed from halt to normal operation is as figure3.



图 3 Figure3

#### 5.4.2.2 低速断续运转模式如图 4

The variation mode under a make-and-break operation mode at a low rotation speed is as figure4.

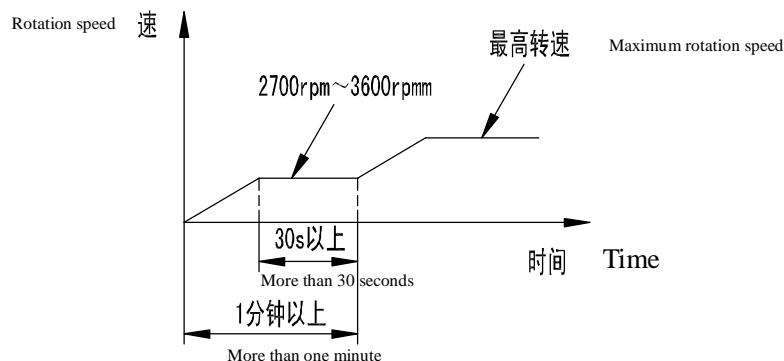

图 4 Figure4

#### 5.5 电流限制 Limitation of the current

对于搭载有直流无刷永磁电机的变速压缩机，其电机端子间的电流峰值（含瞬时峰值）不应大于本规格书 2.2 中的电流峰值，以防永磁铁退磁。

For BLDCM equipped with a inverter compressor, peak current(including instantaneous peak) of motor terminal should be less than or equal to the value contained in contract 2.2 of this specification, to avoid permanent magnet demagnetization.

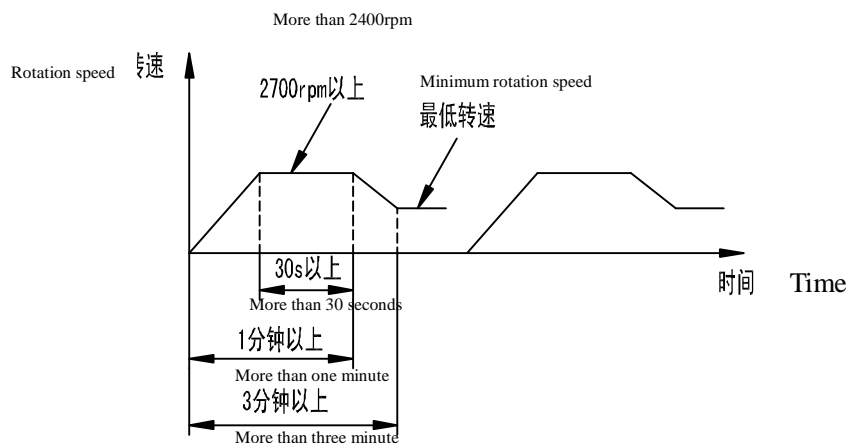
5.6 工质充填量以在压缩机注油量的 2.5 倍（重量比）以下作为原则。超过 2.5 倍时，应进行充分的耐久性评价。

The charging quantity of refrigerant is based on the principle that the charging quantity is less than 2.5 times (weight ratio) of the oil quantity of the compressor. When the weight ratio is over 2.5, an adequate durability evaluation should be conducted.

### 6. 压缩机的使用和安装注意事项 Application and Installation Considerations of the Compressor

6.1 请按本规格书要求的牌号和用量给压缩机注入冷冻机油。

Please inject oil into the compressor at required trademark and quantity by this specification.

6.2 控制压缩机油量 Oil management

压缩机须连续回油，制冷系统构造中不应有存油部分。压缩机正式装配前，应先连续运转 30min 后停机称重，当质量下降超过 10g 时，应补充相应质量的冷冻机油（RL68H）。如此反复

几次方能装配。

The oil should be returned continuously to the compressor and the structure of the refrigerating system should not make oil stay in the system. Before the compressor is assembled, it should be run till 30 minutes and weighed. When the weight reduction is over 10 grams, the equivalent mass of oil (RL68H) should be injected in the compressor. The compressor could be assembled formally after several loops mentioned above.

6.3 在距离压缩机壳体 $\leq 5\text{mm}$ 处检测的压缩机工作时的排气温度必须满足： $\leq 105^\circ\text{C}$ ，若超过此值应使压缩机停止工作。

The discharge temperature of a working compressor which is detected at a distance no more than 5mm from the shell of the compressor must be no more  $105^\circ\text{C}$ . Otherwise the compressor must be turned off immediately.

6.4 压缩机的工作电流应满足： $\leq 14\text{A}$ ，若超过此值应使压缩机停止工作。

The operating current of the compressor must be no more than 14 A, otherwise the compressor must be turned off immediately.

6.5 制冷系统中的真空度、水份及杂质 Vacuum, moisture content and impurity content of the refrigeration system

制冷系统的真空度，常温下，制冷剂充注前应在  $20\text{Pa}$  以下，含水量应在  $40\text{ppm}$  以内，热交换器和配管内侧表面杂质量应在  $0.03\text{g}/\text{m}^2$  以下，但不允许有金属粉末，并清洗掉在制造过程中残留的三氯乙烯、酸、碱、油和清洗剂等。钎焊时应在系统内注入干燥氮气以防氧化皮的发生。

At normal temperatures, the vacuum of the refrigeration system should be less than  $20\text{Pa}$  before the refrigerant is injected; the moisture content should be less than  $40\text{ppm}$ ; the impurity contents of the heat-exchanger and surface of the inside of the pipe should be no more than  $0.03\text{g}/\text{m}^2$ . It is required that no metal powders exist and that all residual trichloroethylene, acid, alkali, oil and abluent remained in producing be washed off. Dry nitrogen should be injected to the system during the process of brazing in case of oxide coating.

6.6 压缩机的保管及组装 Keeping and assembling of the compressor

压缩机应保存在灰尘少、温度变化小的环境中，质量保证的保管期为 1.5 年。使用时才允许拔掉进出气管盲塞。在拔取盲塞后，放置在大气中的时间不超过 5 分钟。

The compressor should be stored in an environment with little dust and temperature variation. Storing period with quality insurance is 1.5 years. Removal of the stem in discharge tube is only allowed under usage. The compressor should be exposed to the air no more than 5 minutes after the stem is removed.

压缩机应在  $5^\circ$  以内倾斜角度条件下运转。超出此范围运转时需进行充分验证，确保压缩机不失效，并告知压缩机供应商。

The compressor should work under the condition of a-less-than- $5^\circ$  slope. The efficacy of the compressor should be fully tested and the supplier of the compressor should be notified whenever the slope exceeds  $5^\circ$ .

6.7 运转注意事项 Operation considerations

6.7.1 绝对禁止压缩机用空气或空气与工质的混合物运转。这样有可能会产生爆炸。

The compressor's operating with air or a mixture of air and refrigerant is absolutely prohibited, which may lead to an explosion.

6.7.2 压缩机不能逆转。逆转后的压缩机不能再使用。

The compressor cannot operate backwards. Any compressor that has operated backwards cannot be put into service again.

6.7.3 制冷循环系统在真空状态下（未封入工质等），不可运行压缩机。

The compressor cannot operate when the refrigeration system is in vacuum (when refrigerant is not charged).

#### 6.8 工质充填 Charging of refrigerant

工质初次充填或维修充填，不用压缩机，而由高压侧充填，不能从吸入侧液态充填或直接吸入。从吸入侧充填时，必须通过蒸发器以气态吸入。

The compressor is not used in the first charging and repairing charging of the refrigerant. The refrigerant should be charged from the side of the high-pressure in the cooling system. It can neither be charged at the sucking side in the form of liquid nor be directly sucked. When charged at the sucking side, the refrigerant must be sucked through the evaporator in the form of gas.

在充填制冷剂 15 分钟之内，压缩机应运转 20 秒以上，以确保润滑。

The compressor must operate for more than 20 seconds within 15 minutes after the refrigerant is charged to ensure lubrication.

#### 7. 控制器的使用注意事项 Using considerations of the controller

控制器 MCE-200A 使用说明详见规格书 MCE-200B/V01。

The using considerations of the controller of MCE-200A is defined in the specification as MCE-200A/GS-001.

#### 8. 零件及图样清单 Parts and Drawing List

零件名称 Parts Name	代号 Code	数量/套 QTY/Set	备注 Remarks
压缩机 Compressor	TC2-M014Y4	1	外形图 Shape
减振垫 Absorber Suppor	AZ003-55102	3	
控制器 Controller	MCE-200B/V01	1	
			电气接线图 Electric Wiring Diagram
			压缩机附件安装图 Accessories installation diagram

#### 9. 规格书有效期 The Period Of Validity

本规格书经贵公司确认之日后即生效。若更改须重新确认生效，以前之规格书自动失效。

This specification takes effect from the day of the costumer's confirmation with both parties' authorized signing. If any alteration of the specification takes place, this specification should be reaffirmed to be valid, and any former copy of this specification will automatically expire.



名称 Name	压缩机外形图 Compressor shape	代号 Code	YZ-DW-01
---------	-------------------------	---------	----------

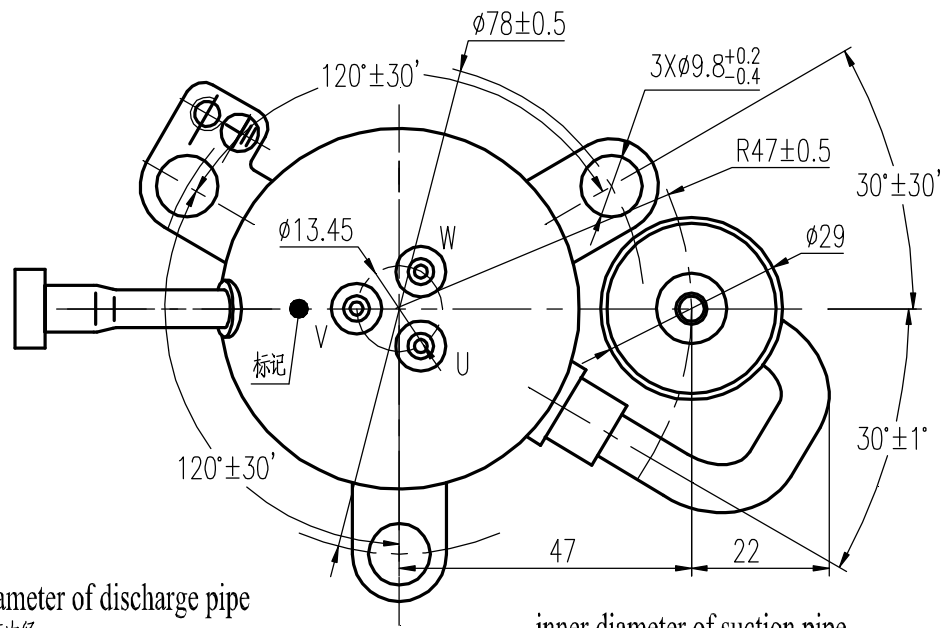
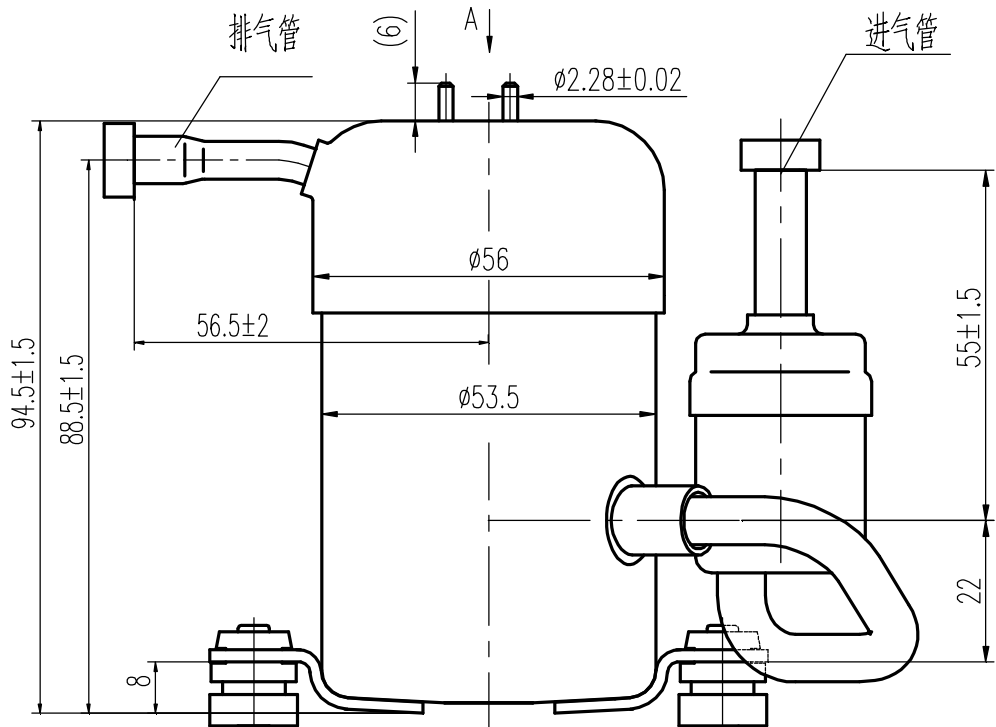

inner diameter of discharge pipe

排气管内径

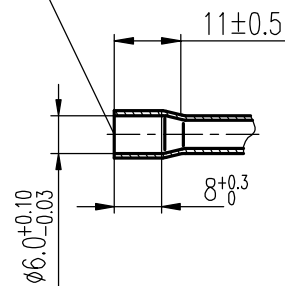

inner diameter of suction pipe

进气管内径

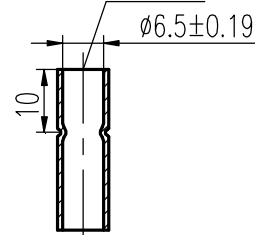

单位: mm

Dimension: mm

名称 Name

压缩机接线图 Compressor electric wiring diagram

代号 Code

YZ-DW-02

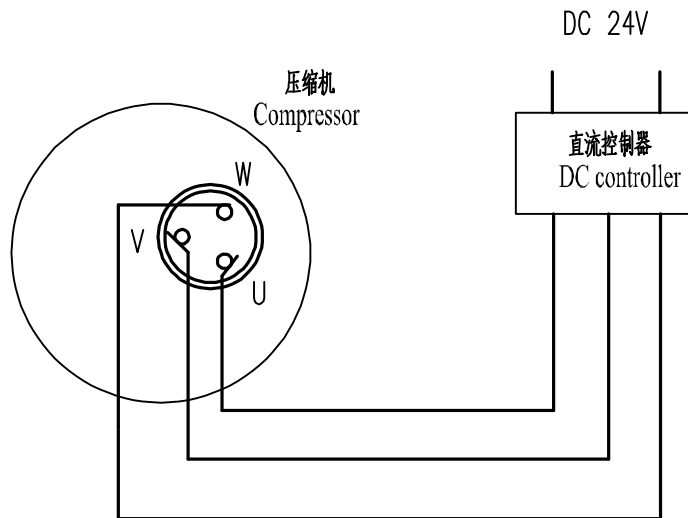

U、V、W：三相接线端子

U、V、W：Junction terminals

当压缩机工作电流 $\geq 14\text{A}$ 时，控制器应保护。

The controller must be turned off immediately when the operating current of the compressor  $\geq 14\text{ A}$ .

单位：mm

Dimension：mm

名称 Name

减振垫 Absorber Suppor

代号 Code

AZ003-55102

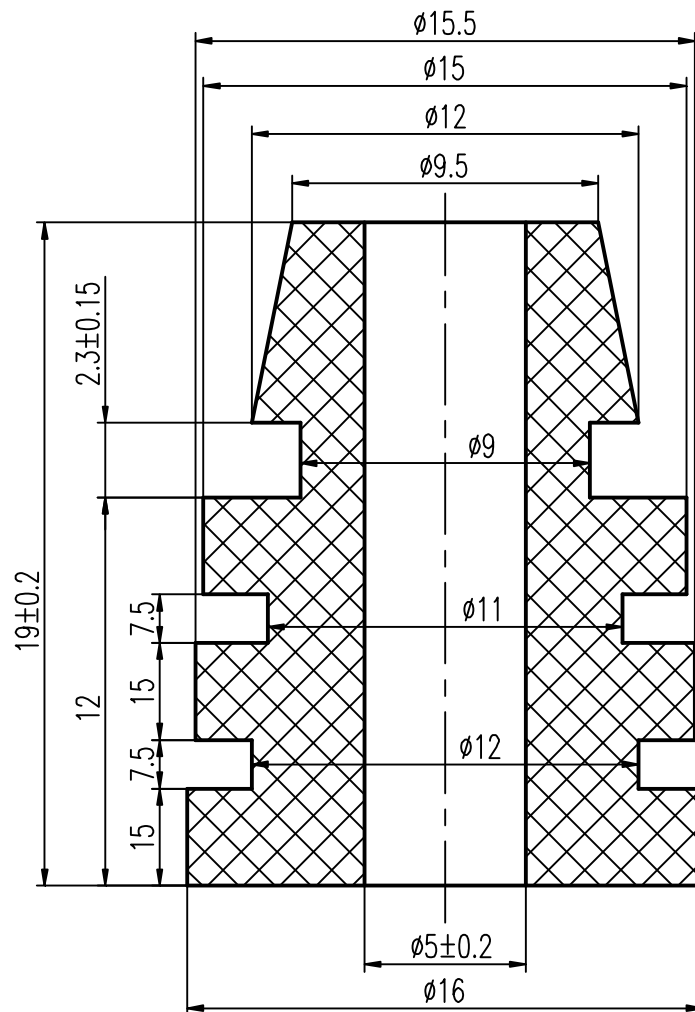

材料EPDM

Material:EPDM

硬度: 邵氏A 33 $\pm$ 3

Hardness: Shore A 33 $\pm$ 3

单位: mm

Dimension: mm

名称 Name

压缩机附件安装图 Accessories installation diagram

代号 Code

YZ-DW-05

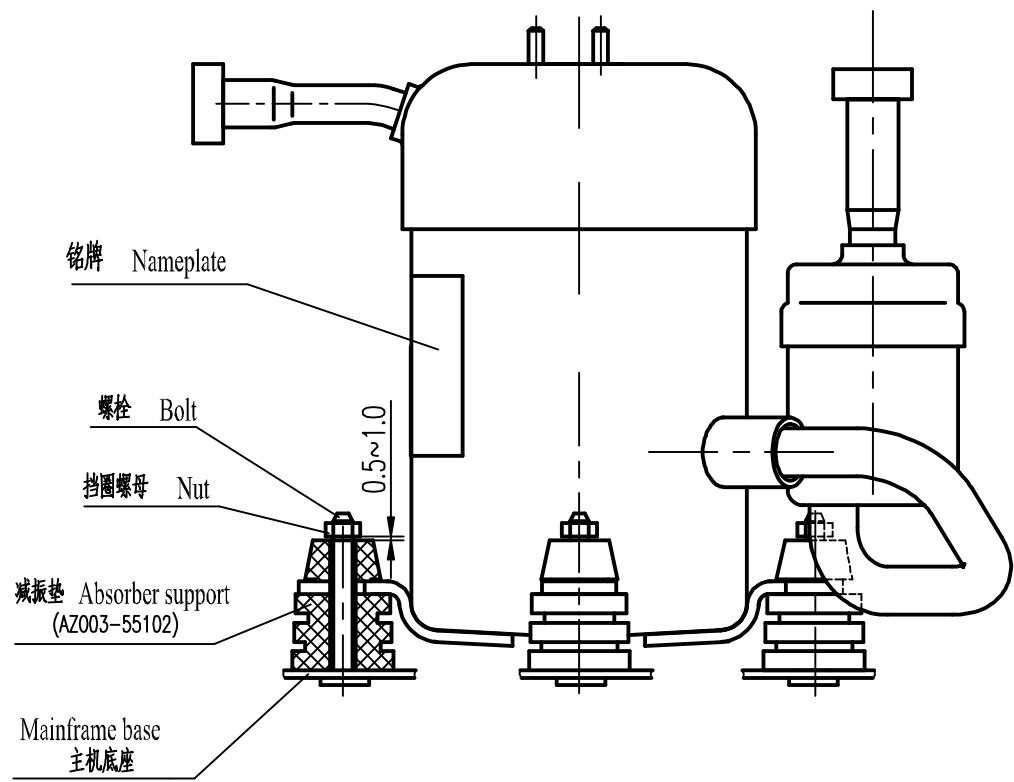

单位: mm

Dimension: mm